

MONARCH

Materials Group Inc.

EZ THERMAL COVER® Assembly and Installation

EZ Cover Installation Instructions (Read the instructions completely before installing the cover).

Materials & Tools Needed:

Check the contents of the plastic bag included with the EZ Cover, there should be:

- 4 - Machine Screws
- 4 - Spring-Clips
- 4 - Ties
- 4 - Self tapping Screws
- 4 - Square nuts

Note: You will also need a Phillips Screwdriver No. 2

EZ Thermal Cover Installation:

1.) Assemble the Spring-Clips and Ties as shown:

- Insert the Machine Screw through the Spring-Clip & Tie
- Place the square nut into the Tie
- Tighten Machine screw until flush with nut

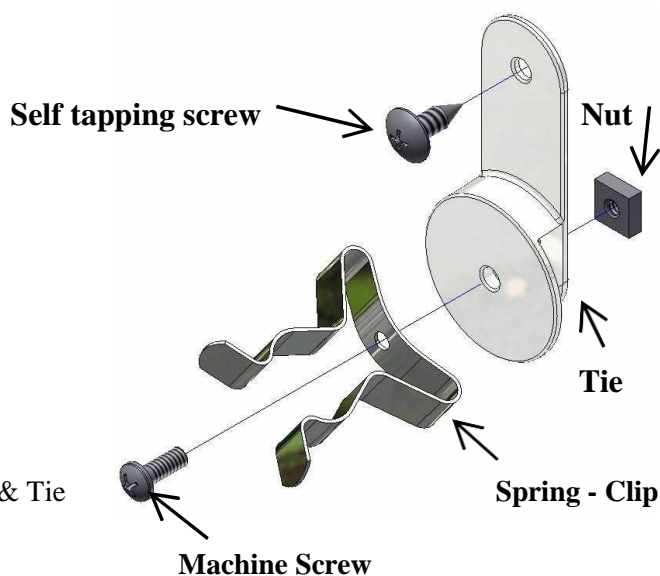

2.) Mount the Spring-Clip assembly using the pre-drilled holes and self tapping screws. Tighten and then loosen the self tapping screw a ¼ turn so that the Tie swivels.

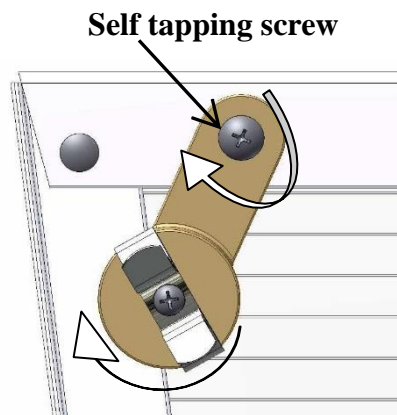
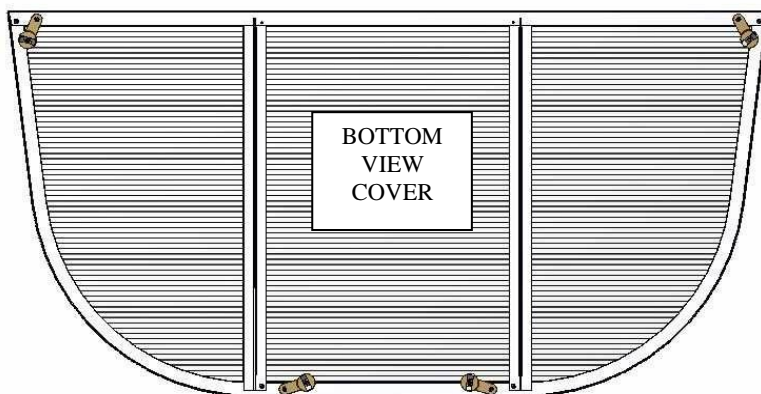

- 3.) Place the Cover on top of your window well and rotate the Ties and the Spring-clips for proper alignment with the upper lip of the well.

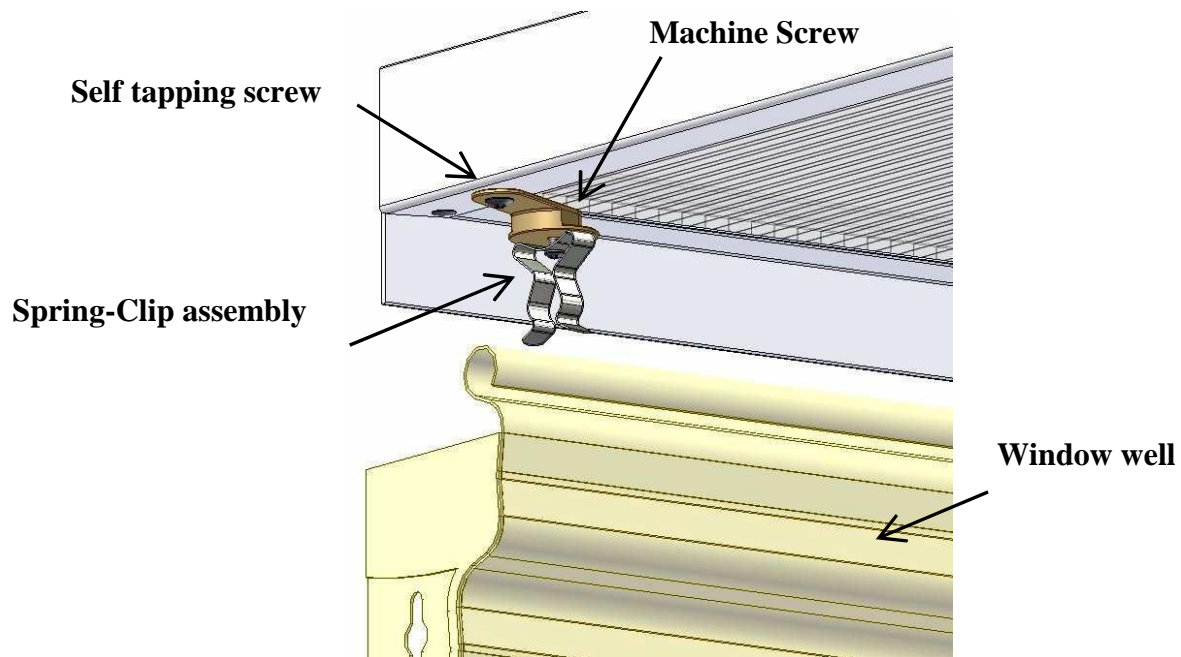

If necessary loosen the Machine screw to rotate the Spring-Clip.

Caution: Loosen the screw just enough to rotate the Spring-clip!

- 4.) The removable cover is held in-place by Spring-Clips.

Check egress: Pull the cover up and check the hold down.

- 5.) If desired, tighten the Machine screws on the Spring-Clips to increase or loosen the Machine screws to decrease to hold down.

